

CLICKSYS™

INSTALLATION MANUAL

v. 1.0

© 2009 by Unirac, Inc. All rights reserved.
Pub 090501-1ii, May 2009

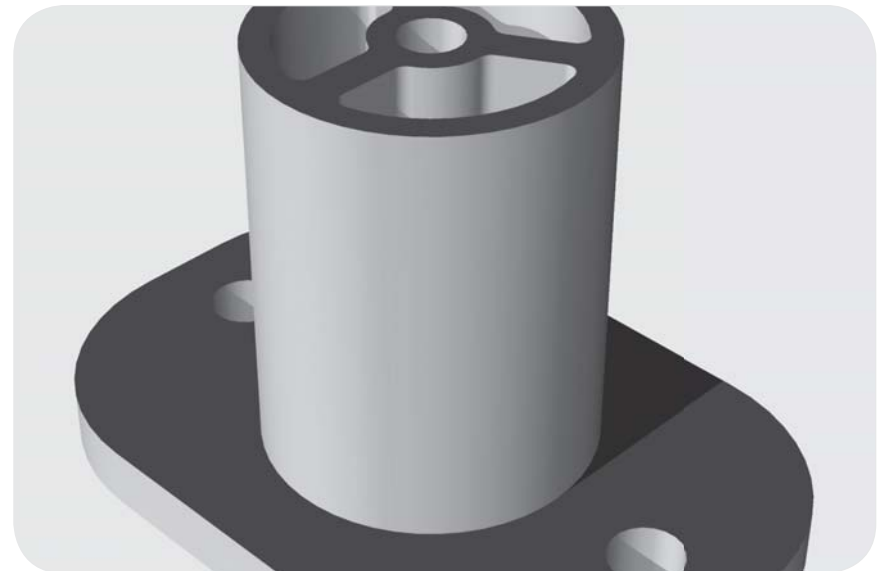
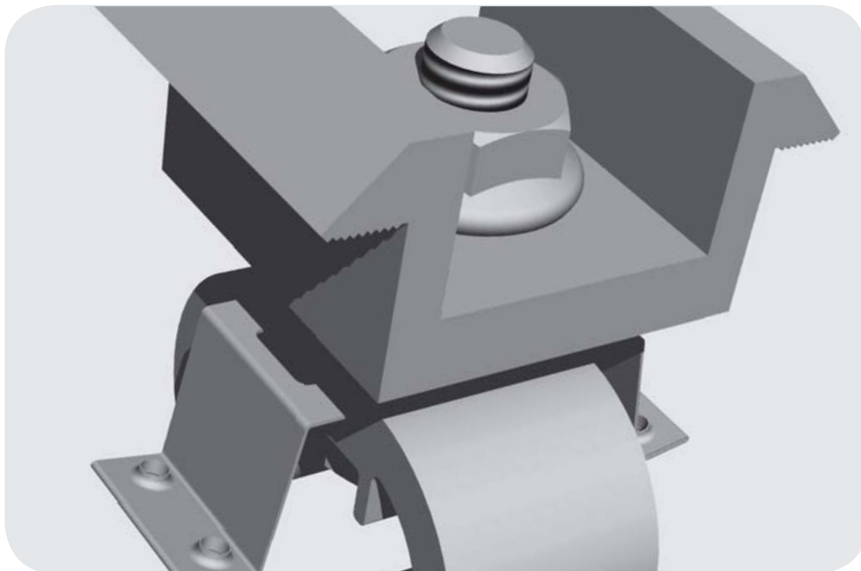

1411 Broadway Boulevard NE
Albuquerque NM 87102-1545 USA

www.clicksys-beam.com

IMPORTANT!

Unirac Inc. makes no warranty of any kind with regard to this material, including, but not limited to, the implied warranties of merchantability and fitness for a particular purpose.

The information in this document is subject to change without notice.

Unirac shall not be liable for errors contained herein or for incidental or consequential damages in connection with the furnishing, performance, or use of this material.

This document contains proprietary information that is protected by copyright. All rights are reserved. No part of this document may be photocopied, reproduced, or translated to another language without the prior written consent of Unirac.

Unirac Inc.
Marketing Department
1411 Broadway Boulevard, NE
Albuquerque, NM 87102-1545

© Unirac Inc., 2009. All rights reserved.

CLICKSYS™ is a registered trademark of Unirac Inc. in the United States of America and other countries.

INTRODUCTION

CLICKSYS™

Thank you for choosing CLICKSYS™. This quick start guide provides easy step-by-step installation instructions. For additional information, please visit us at www.clicksys-beam.com.

BEFORE YOU BEGIN

1 Verify that all of the components are included and consistent with your order.

2 To avoid conflicts, never modify or combine Unirac's CLICKSYS™ with components that are not made for CLICKSYS™. Doing so will void any warranty associated with CLICKSYS™.

COMPONENTS

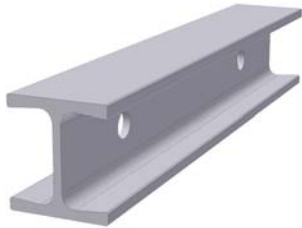

Beam (144")

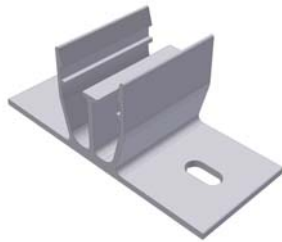

2 Flange Connection *
Shown without butyl option
(2) #14-13 X 3" Concealor™ screws



1 Flange Connection
(1) 5/16" x 3-1/2" Zinc Plated Lag Bolt
(1) Washer

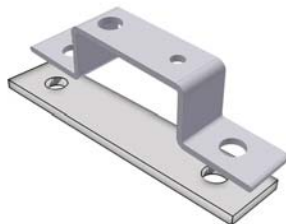

Beam Splice **
Shown without grounding option
(2) Stainless steel hex bolt
(2) Nut

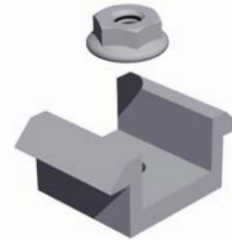

Mid Clamp
(1) Stainless steel hex bolt
(1) Nut
(1) Slider



End Clamp
(1) Stainless steel hex bolt
(1) Nut
(1) Slider



UGC-2 Grounding

* Butyl (optional with 2 Flange Connection)

** WEEB 9.5 Grounding (optional with Grounding Splice Kit)

OPTIONAL ATTACHMENTS



2-Piece Aluminum Standoff

- (2) 5/16" x 3-1/2" Zinc Plated Lag Bolt
- (1) 1 Flange Connection
- (1) 3/8" x 3/4" Hex Head Bolt
- (1) 3/8" x 1-3/4" EPDM Washer

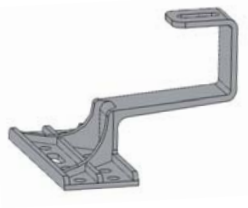

CreoTecc Tile Hook (Top)

- (2) 5/16" x 3-1/2" Zinc Plated Lag Bolt
- (1) 3/8-16 x 3/4" Hex Head Bolt
- (1) 3/8" Hex Head Nut

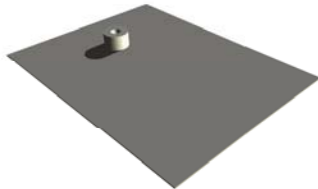

PV Quick Mount

- (1) 5/16" x 3-1/2" Stainless Steel Lag Bolt
- (1) 5/16" Sealing Washer
- (1) 5/16" EPDM Washer
- (1) 1 Flange Connection

PLANNING YOUR CLICKSYS™ INSTALLATION

The installation can be laid out with beams parallel to the rafters or perpendicular to the rafters. Note that CLICKSYS™ beams make excellent straight edges for doing layouts.

Center the installation area over the structural members as much as possible.

Leave enough room to safely move around the array during installation. Some building codes require minimum clearances around such installations, and the user should be directed to also check 'The Code'.

The width of the installation area equals the length of one module.

The length of the installation area is equal to:

- the total width of the modules,
- plus 1 inch for each space between modules (for mid-clamp),
- plus 3 inches (1½ inches for each pair of end clamps).

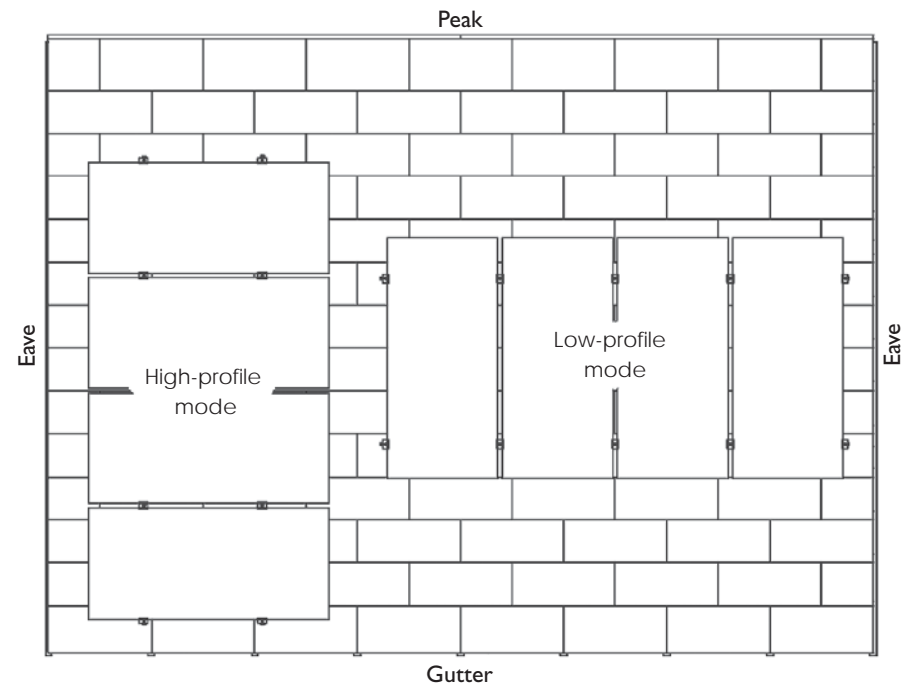

To speed installation, mark beam at approximate proper foot space before clicking connections to beam.



NOTE: Most installations do not overhang on attachment more than 18" of beam.

INSTALLING CLICKSYS™

Step 1: Attach beam to 2 Flange Connection or 1 Flange Connection

-  **NOTE:** Always engage one side before clicking connection into beam.
 **NOTE:** Do not use connection if the engagement features on the connection are bent or damaged.

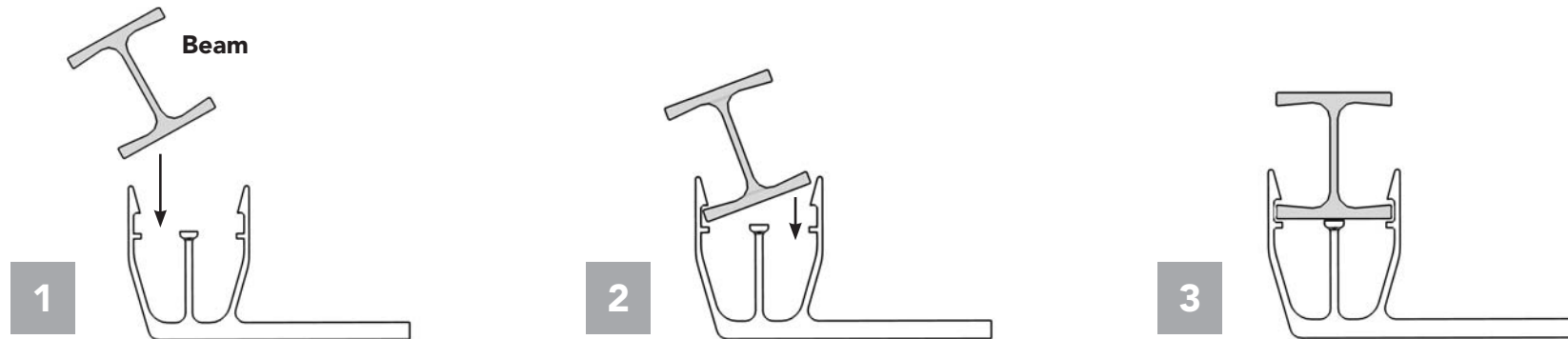

Step 2: Attach 2 Flange Connection or 1 Flange Connection to rafter

-  **NOTE:** When using 2 Flange Connection w/Butyl Pad, remove liner before installing screws.

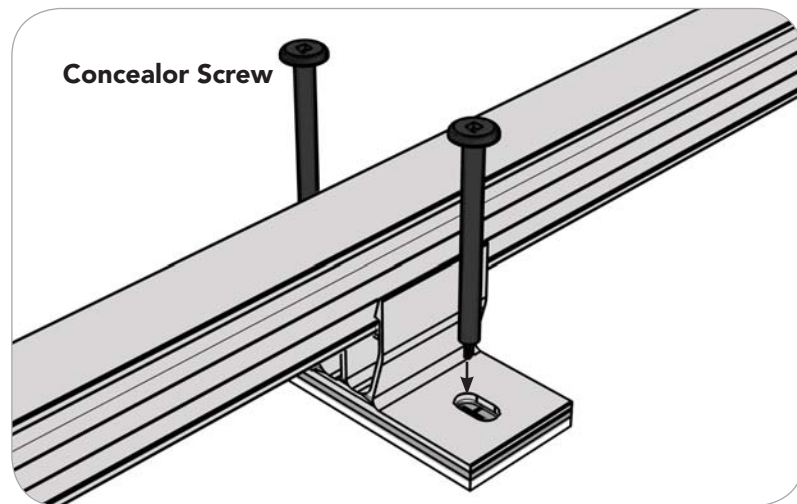

2 Flange Connection Option

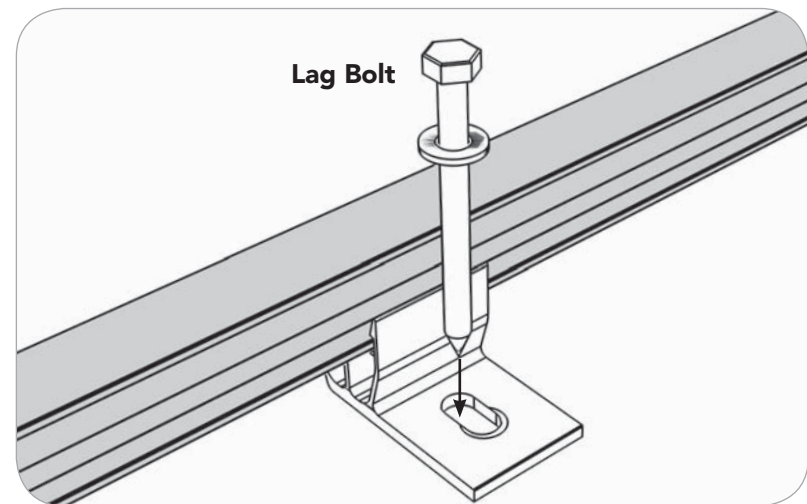

1 Flange Connection Option

Step 3: Install appropriate number of sliders and optional UGC-2 grounding clips

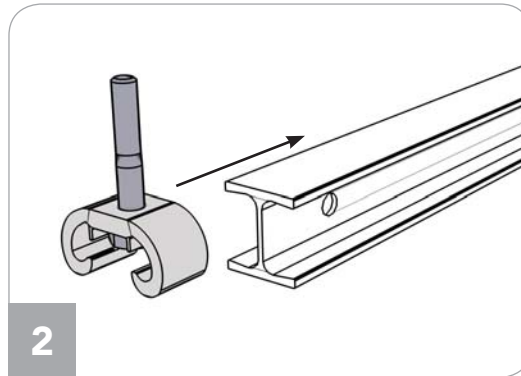
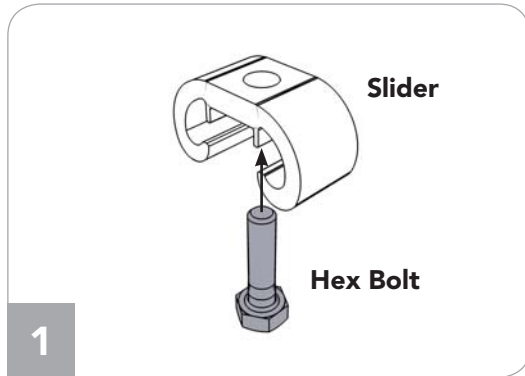

Step 4A: Install Splices (Option 1) - Use when splicing two beams at a connection

 **NOTE:** Tighten nut to 75 inch pounds with anti-seize

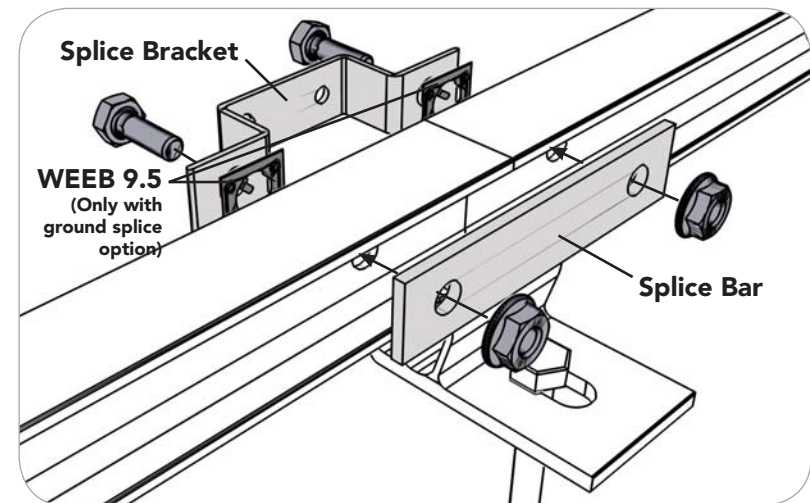
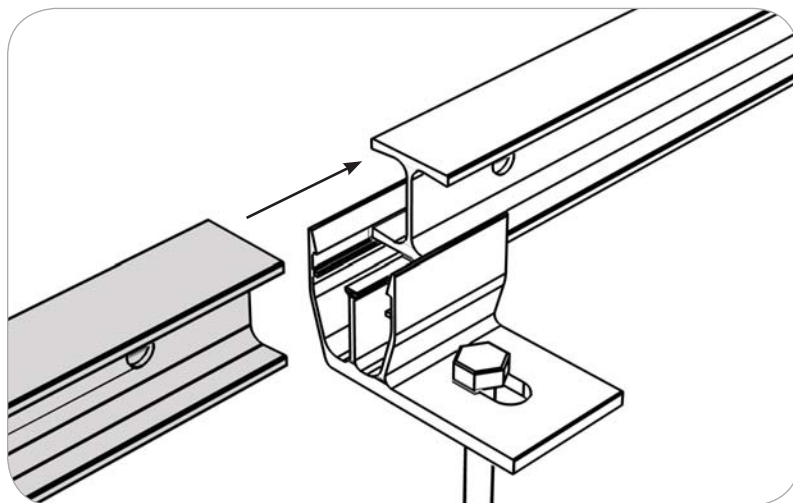

Step 4B: Install Retaining Clip (Option 2) - Use as a retaining clip on single beam applications

-  **NOTE:** Tighten nut to 75 inch pounds with anti-seize.
NOTE: Sliders cannot be moved along beam once retaining clip is installed.

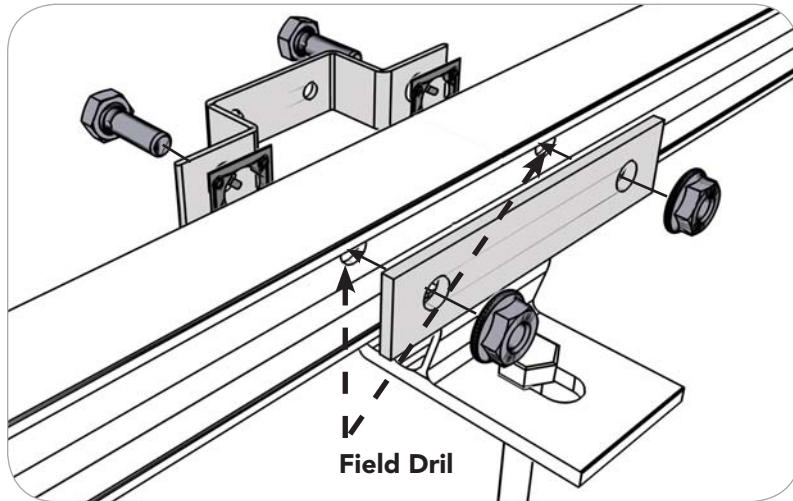

NOTES ON THERMAL EXPANSION:

CLICKSYS is designed to minimize the effects of thermal expansion by allowing the beams to expand and contract independently between connections and attachments. To minimize the effect of thermal expansion, restrict continuous beam lengths to 36 feet or three standard beam lengths.

Step 5: Installing Grounding Lugs

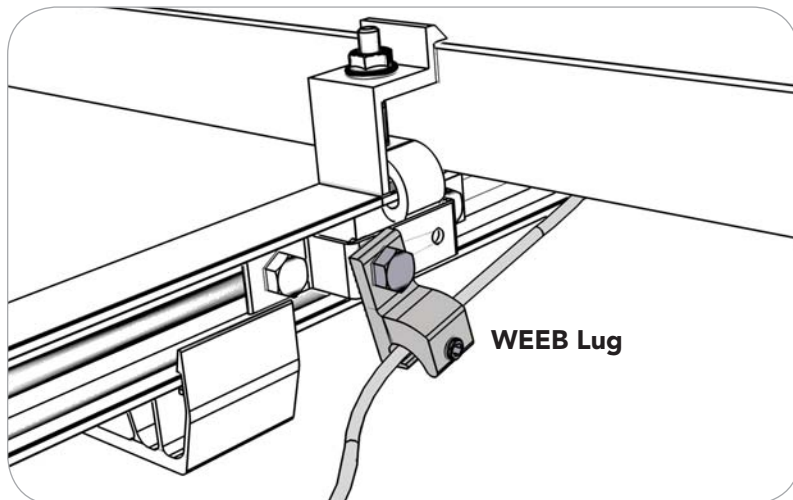

Step 6: Attach modules using top mounting hardware

 **NOTE:** Tighten nut to 75 inch pounds with anti-seize.

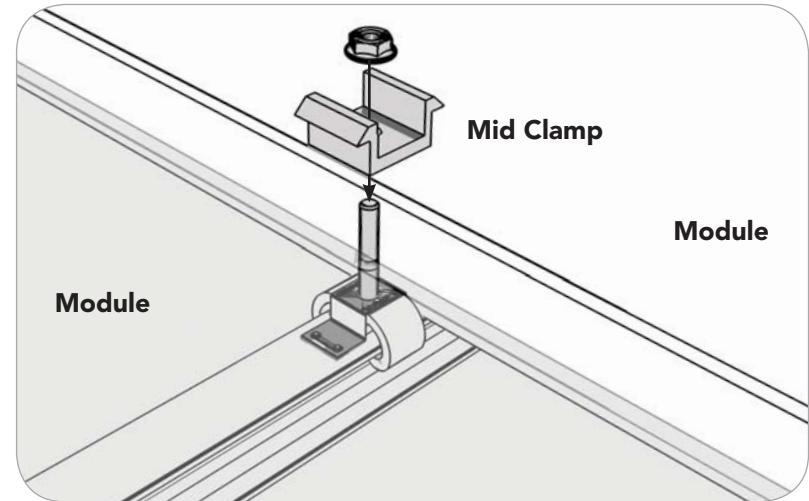
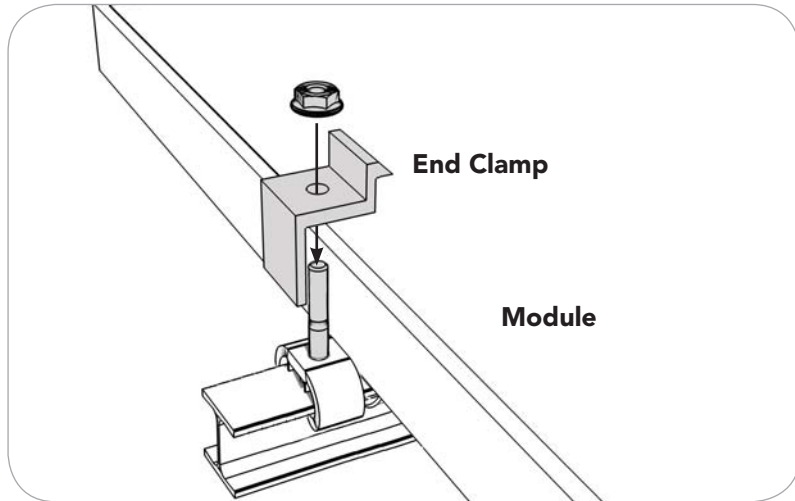

WARRANTY

10 year limited Product Warranty

Unirac, Inc., warrants to the original purchaser ("Purchaser") of product(s) that it manufactures ("Product") at the original installation site that the Product shall be free from defects in material and workmanship for a period of ten (10) years, from the earlier of 1) the date the installation of the Product is completed, or 2) 30 days after the purchase of the Product by the original Purchaser.

The Warranty does not apply to any foreign residue deposited on the finish. All installations in corrosive atmospheric conditions are excluded. This Warranty does not cover damage to the Product that occurs during its shipment, storage, or installation.

This Warranty shall be VOID if installation of the Product is not performed in accordance with Unirac's written installation instructions and design specifications therein, or if the Product has been modified, repaired, or reworked in a manner not previously authorized by Unirac IN WRITING, or if the Product is installed in an environment for which it was not designed. Unirac shall not be liable for consequential, contingent or incidental damages arising out of the use of the Product by Purchaser under any circumstances.

If within the specified Warranty period the Product shall be reasonably proven to be

defective, then Unirac shall repair or replace the defective Product, or any part thereof, in Unirac's sole discretion. Such repair or replacement shall completely satisfy and discharge all of Unirac's liability with respect to this limited Warranty. Under no circumstances shall Unirac be liable for special, indirect or consequential damages arising out of or related to use by Purchaser of the Product.

Manufacturers of related items, such as PV modules and flashings, may provide written warranties of their own. Unirac's limited Warranty covers only its Product, and not any related items.

CLICKSYS™

INSTALLATION MANUAL v. 1.0

www.clicksys-beam.com